

# TECHNIFLO

## Operation and Maintenance

P W - N and P W - N - K Series

### C O N T E N T S

	Page
1 . INTRODUCTION.....	2
2. UNPACKING AND INSPECTION.....	2
3. SPECIFICATIONS TABLE AND INSTALLATION DIMENSION.....	2
4. TYPE INDICATION AND PARTS LIST.....	3
5. INSTALLING , PIPING.....	4
6. PRECAUTIONS FOR OPERATION.....	5
7. MAINTENANCE AND INSPECTION.....	6
8. PREVENTIVE MAINTENANCE.....	7
9. DISASSEMBLY AND ASSEMBLY.....	7
10. EXPLODED VIEW.....	8
11. TROUBLESHOOTING.....	9

## 1. INTRODUCTION

You are kindly requested to read this manual carefully before unpacking and installing the Pump.

## 2. UNPACKING AND INSPECTION

Check following points and if any are incorrect, please refer to your supplier.

- 1) Does the description on the nameplate comply with your order?
- 2) Are all items delivered?
- 3) Is there any damage to the pump or /and parts caused by an accident during transport?
- 4) Are all bolts tightened?

## 3. SPECIFICATION TABLE AND INSTALLATION DIMENSION

Model	Connection Method		S.G.	Performance , 50/60Hz		Max Self Priming Lift head at S.G 1.0 (m)	Motor kW 2860/3440
	Flange(mm) In x Outlet	Thread (") In x Outlet		Capacity-discharge head at specified point (l/min at m)	Max capacity – max discharge (L/Min - m)		
400PW-N	40A x 40A	1½" x 1½"	1.1	140 at 7 / 140 at 6	240-10.5 / 240-9.5	3	0.37
			1.3	160 at 5 / 120 at 6	200-8.5 / 200-8.5		
401PW-N	40A x 40A	1½" x 1½"	1.1	200 at 10 / 200 at 8	320-16 / 320-15	3.3	0.75
			1.3	160 at 10 / 160 at 9	290-14 / 290-12.5		
402PW-N	50A x 40A	2" x 1½"	1.1	250 at 16 / 250 at 16	470-24.5 / 470-20.5	4	1.5
			1.3	265 at 14 / 265 at 13	450-22 / 450-19		
403PW-N	50A x 40A	2" x 1½"	1.1	280 at 21 / 290 at 19	570-26 / 570-23	4	2.2
			1.3	240 at 18 / 240 at 18	550-23 / 550-21		
405PW-N	50A x 40A	2" x 1½"	1.1	330 at 25 / 330 at 26	600-32 / 600-32.5	4	3.7
			1.3	330 at 25 / 320 at 23	600-32 / 570-31		
400PW-N-K	40A x 40A	1½" x 1½"	1.2	140 at 6.5 / 140 at 6	240-10 / 240-9	3	0.37
			1.5	140 at 5.5 / 140 at 5.5	240-8.5 / 240-7.5		
			1.9	140 at 5 / 120 at 5.5	240-7.5 / 240-6.5		
401PW-N-K	40A x 40A	1½" x 1½"	1.2	170 at 10.5 / 180 at 10	320-15 / 320-14	3.3	0.75
			1.5	160 at 9.5 / 190 at 8	320-13 / 320-12		
			1.9	160 at 8 / 220 at 6.5	320-11 / 320-10.5		
402PW-N-K	50A x 40A	2" x 1½"	1.2	210 at 17 / 200 at 17.5	470-23 / 470-19.5	4	1.5
			1.5	250 at 13.5 / 230 at 13	470-20 / 470-16.5		
			1.9	230 at 12 / 270 at 11.5	470-20 / 470-14		
403PW-N-K	50A x 40A	2" x 1½"	1.2	360 at 17 / 360 at 16	570-24.5 / 570-21.5	4	2.2
			1.5	340 at 15 / 380 at 13	570-21 / 570-18.5		
			1.9	360 at 12.5 / 340 at 12	570-18 / 570-16		
405PW-N-K	50A x 40A	2" x 1½"	1.2	330 at 24 / 330 at 24.5	600-30 / 600-30.5	4	3.7
			1.5	380 at 19 / 330 at 21	600-26 / 600-26.5		
			1.9	360 at 17 / 330 at 18	600-22 / 600-22.5		

1. Max self-priming lift head is shown when horizontal pipe length of section inlet is max 0.5m.

2. Max self-priming lift head is S.G. at 1.0

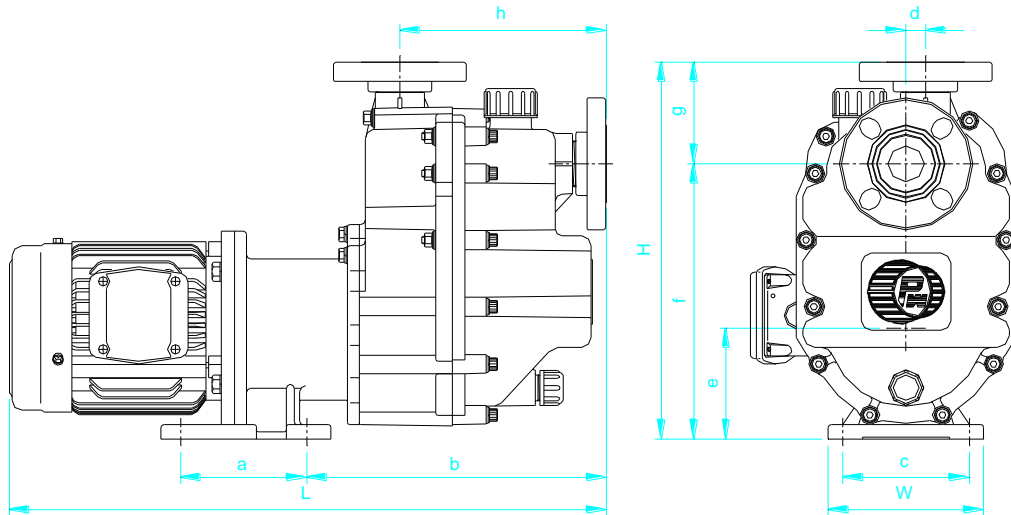

Dimensions in mm

Model	W	H	L	a	b	c	d	e	f	g	h
400PW-N / PW-N-K	160	390	613	130	308	130	20	115	285	105	212
401PW-N / PW-N-K	160	390	615	130	308	130	20	115	285	105	212
402PW-N / PW-N-K	260	420	794	200	333	208	30	115	315	105	250
403PW-N / PW-N-K	260	420	794	200	333	208	30	115	315	105	250
405PW-N / PW-N-K	260	436	866	200	333	208	30	130	330	105	250

Remark : 1. The size in above table is shown with IEC motor.  
 2. Over all size & construction may be changed without notice.

#### 4. TYPE INDICATION AND PARTS LIST

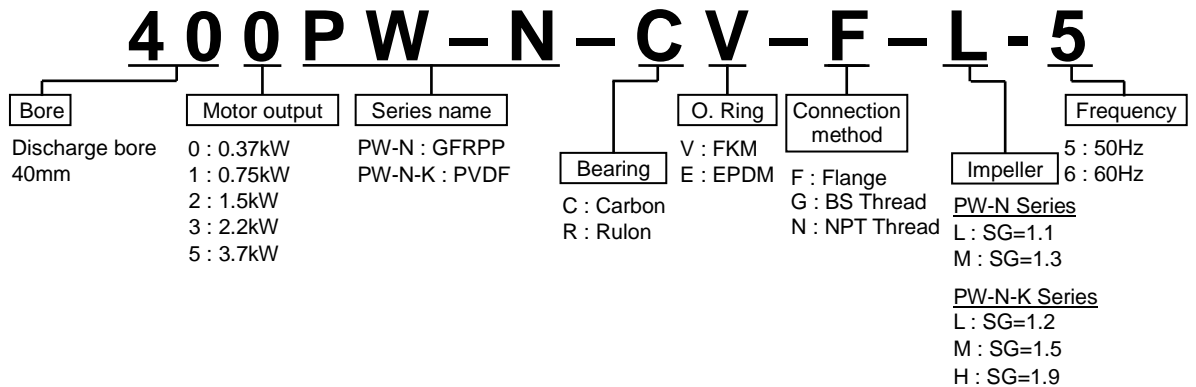

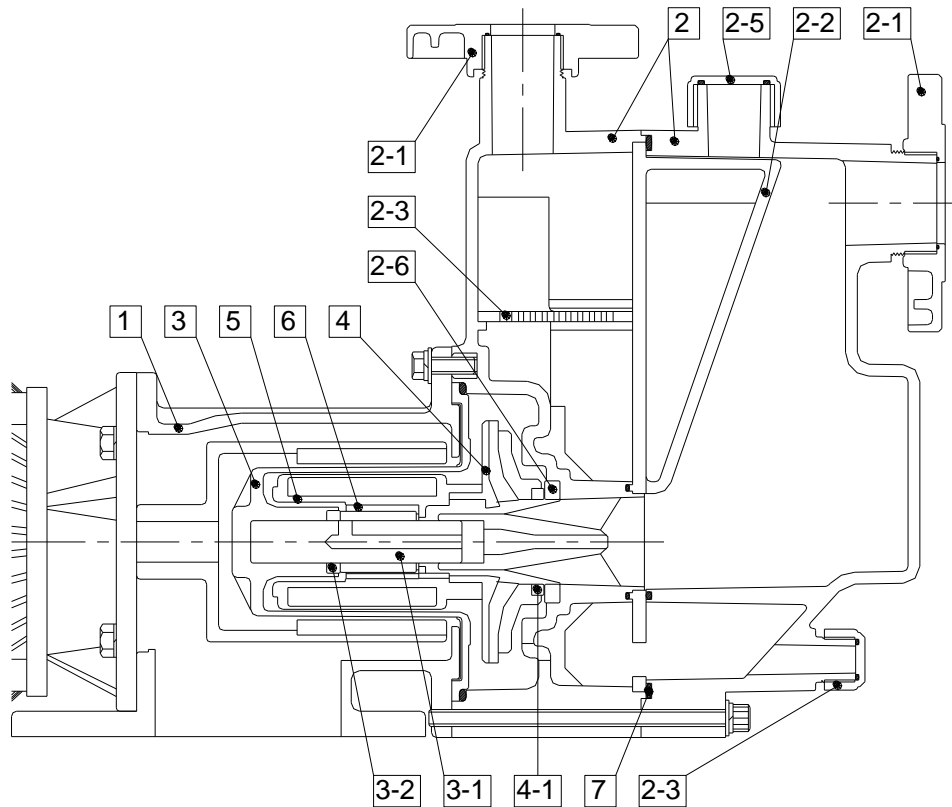

	400/401/402/403/405PW-N		400/401/402/403/405PW-N-K			
1. Bracket	CV	CE	RV	CV	RE	CE
2. Self-priming chambers	FC-20		FC-20			
2-1. Flange	GFRPP		PVDF			
2-2. Telescopic piece						
2-3. Filter						
2-4. Drain cap						
2-5. Filler cap						
2-6. Thrust pad	99.5% Alumina ceramic		99.5% Alumina ceramic			
3. Rear casing	GFRPP		CFR ETFE			
3-1. Spindle	99.5% Alumina ceramic		99.5% Alumina ceramic			
3-2. Rear thrust pad	99.5% Alumina ceramic		99.5% Alumina ceramic			
4. Impeller	GFRPP		CFR ETFE			
4-1. Mouth ring	Rulon LD		Rulon LD			
5. Magnet capsule	GFRPP		CFR ETFE			
6. Bearing	Carbon		High density carbon			
7. Gasket	FKM	EPDM	FKM			
8. O. Rings	FKM	EPDM	FKM			

## 5. INSTALLING , PIPING

- 1) When air enters the connecting joints of the suction pipe, priming becomes almost impossible, resulting in pump fault.
- 2) When the piping is larger than the pump diameter, self-priming ability is decreased and self-priming impossible. Use a inlet pipe with the same diameter as the pump inlet.
- 3) Select an installation place that is flat and free of vibrations caused by nearby machines.
- 4) The installation position must be as low possible, at a height within the self-priming limit that allows smooth pump performance. If the surface level of the suction tank varies, measure the height from the lowest surface level as the maximum self-priming height to confirm that it will not exceed the self-priming limit.
- 5) Place a sieve at the intake port of the piping to prevent foreign matters from entering the pipe. However, you must periodically clean the sieve to prevent clogging so as to minimize resistance.

- 6) Handle the pump carefully so as not to create any impact, the main parts within the pump are made of plastic.
- 7) The pump can be used indoors or outdoors. There should be sufficient space around the pump to enable easy and efficient maintenance.
- 8) Safety measures should be taken not to expose the motor and power unit to flooding or other natural hazards.
- 9) Contractible joints or create bending sections on the piping to prevent pump deformation and thermal expansion leakage caused by increased liquid temperature.
- 10) Avoid tighten the pump flange excessively. Arrange the pipe flange surface and the pump flange surface parallel to one another
- 11) The weight of the inlet (or discharge) pipes should be completely supported by pipe support apparatuses. Avoid apply weight on the pipes.
- 12) The end of the inlet pipe should be located 0.5 meter or more below the surface of the liquid. The end of the inlet pipe should be a least 1- 1.5D from the bottom of the intake tank. (D=Diameter of inlet pipe).
- 13) It is recommended that a pressure gauge installed on the discharge piping.
- 14) A foot valve should be installed if any of the following conditions exists in the piping:
  - (1) The end of the discharge pipe is located 10 meter higher than the surface of the intake tank.
  - (2) The discharge head is 15 meter or more.
  - (3) The discharge piping is too long.

### PIPING CAUTION

#### PIPING

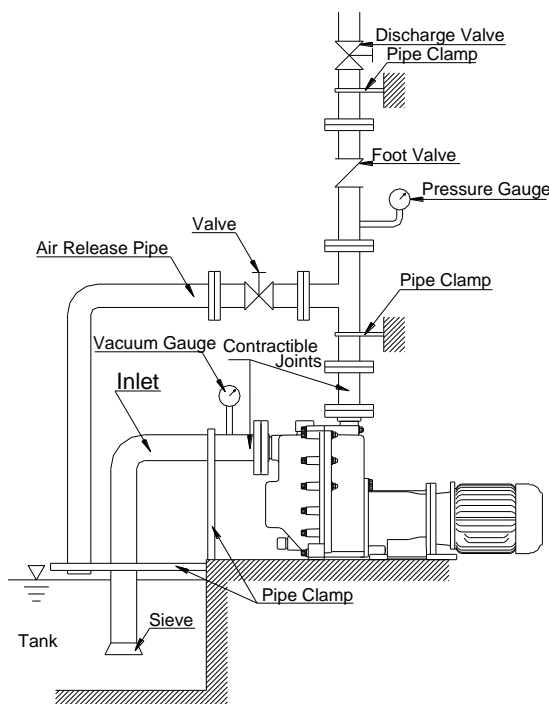

#### PIPING CAUTION

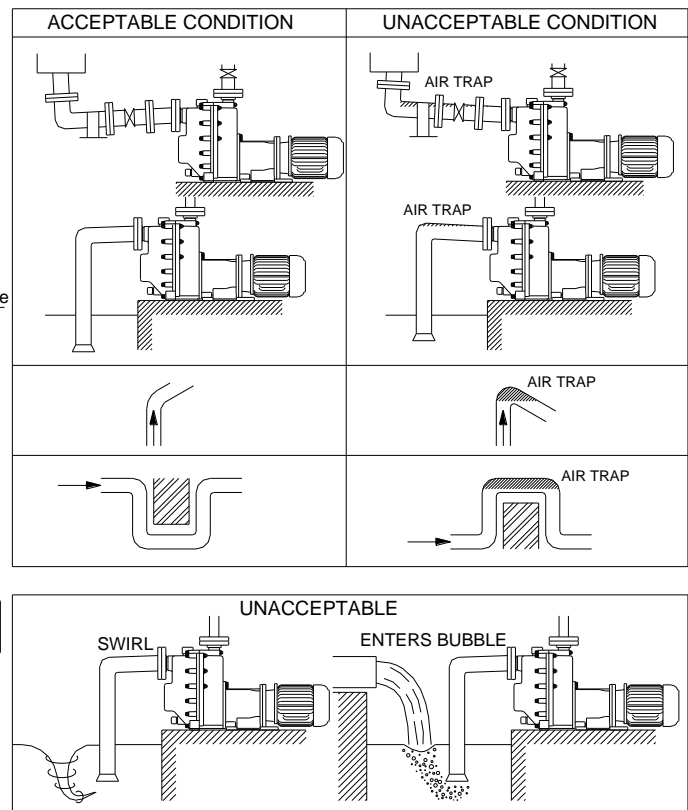

## 6. PRECAUTIONS FOR OPERATION

※Do not operate the pump without positive pressure!

As the abrasion parts are cooled by the pumped liquid, operation without positive pressure or with mis-operation, such as the suction valve closed may damage the internals of the pump. If the pump has been running in these kinds of circumstances or without liquid at all, do not prime the pump with any liquid, but allow the pump to stand and cool down for at least one hour. Priming the pump too soon may result in a thermal shock.

※Influence of liquid temperature

The performance of the pump is not affected by any change in temperature. Liquids may change in viscosity, vapor pressure, corrosiveness, etc when the liquid temperature changes.

Therefore it is necessary to pay full attention to the change in characteristics of the liquid being pumped. Slurry liquids should not be handled.

Operating temperature of liquids pumped (max range for clean water) 0 to 70°C (32 to 158°F) for PW-N series. Operating temperature of liquids pumped (max range for clean water) 0 to 80°C (32 to 176°F) for PW-N-K series. Ambient temperature range 0 to 40°C.

※Change in performance due to specific gravity and viscosity.

- 1) Power requirement is increased by specific gravity but pump performance is not affected.
- 2) More viscosity affect pump performance and power requirement, therefore it's necessary to calculate modified pump performance & modified power requirement in advance.
- 3) Preparations before operation
  - (1)Clean the inside of the piping and tanks completely before installs the pump.
  - (2)Retighten the flange connection bolts and base mounting bolts
  - (3)Turn the motor fan by screwdriver and check that it turns freely.
  - (4)Prime the pump and verify that the pump is filled with liquid.
  - (5)Completely close the discharge valve.
  - (6) The pump is a self-priming type. Before initiating operation, it is necessary for the operator to feed priming water into the pump. Inspect to feed the priming water (or operation liquid) up to the specified level before operation. Otherwise the pump may get worn or seize excessively.

Model	Amount of priming water
400/401PW-N	5.7 litre
402/403/405PW-N	8 litre
400/401PW-N-K	5.7 litre
402/403/405PW-N-K	8 litre

- (7)Verify the direction of rotation of the pump. (C.C.W. from front view)  
When in reverse of exchanges the connection of two phases of the three phase power supply.

4) Precautions during operation

- (1)To operate the pump, close the discharge valve and start the pump. If the pump does not operate, Please check the wiring carefully and correct the fault.
- (2)After the pump is put in operation, gradually open the discharge valve. Use a flow meter and pressure gauge to make sure that the pump is running under your required specification. Check also the differential head of between discharge line and suction line by indication of the discharge and suction pressure gauge.
- (3) Inspect the direction of motor rotation when turn the power ON.. If the direction is reversed, exchange two wires of the three-phase power wires.

5) Cease of operation

- (1)Gradually close the discharge valve. Do not close the discharge by using a solenoid valve or in another quick way. In the event of long discharge piping, the pump is likely to be damaged due to water hammer on closing the discharge too quickly.
- (2)Switch off the motor. Check whether the motor stops smoothly. If not, inspect the internals of the pump.
- (3)When the operation of the pump is stopped for a long period or the liquid is likely to freeze, or crystallize, be sure to drain all the liquid from the pump and the piping.
- (4)When a power failure occurs, the power switch turned off immediately.

**7. MAINTENANCE AND INSPECTION**

- (1)Verify that the pump is running without vibration or any abnormal noise.
- (2)Inspect the suction tank for liquid level and the suction pressure.
- (3)Check the discharge pressure, flow rate and motor current during operation. Then please compare with the pump data to check if the pump operating condition is normal.
- (4)If a stand-by pump is installed, operate it from time to time to make sure it can operate at any time.

## 8. **PREVENTIVE MAINTENANCE**

Preventive Maintenance should be done annually.

The following items should be checked. Inspection of items for overhaul should be taken in reference to the following table:

<b>PARTS</b>	<b>INSPECTION ITEMS</b>	<b>MEASURES</b>
Magnet housing	Evidence of rubbing is the housing fixed in the correct position on the shaft?	Peruse the cause rectify position
Rear Casing	Evidence of rubbing on the inner surface	Replacement.
	Evidence of cracking on the liquid and surface	Replacement.
	Check if there are scratches on the bottom of the rear casing	Replacement.
	Check O-ring for wear creeping and corrosion	Replacement.
Magnet Capsule	Evidence of scrub on the end part and cylindrical housing	Peruse the cause
	Evidence of cracks in the plastics end face and/or cylindrical housing	Replace Magnet Capsule
	Blockage of the passage around inner surface	Clean internal
Impeller	Existence of traces of cavitation	Peruse the cause and clean
	Contamination and clogging on the blades surfaces	Peruse the cause and clean
	Dimensional change of Width	Peruse the cause and clean the impeller
Rear casing chamber	Are there wear or cracks ?	Replacement.
	Tear or expansion of o-ring	Replacement.
	Crack of front thrust ring	Replacement.
Spindle	Crack or wear on surface	Replacement.

## 9. **DISASSEMBLY AND ASSEMBLY**

The magnets used to transmit motor power sufficiently, Please handle with care the at traction between the drive and driven magnets during disassembly and assembly.

Completely close both discharge and suction valves before assembly.

Be very careful when you pump corrosive liquids. There may be a residue in the pump even after a long flushing. Always wear protective clothing and masks when handling contaminated or corrosive liquids.

### 1) Disassembly

(1) Drain the liquid from the pump. At this time completely flush the inside of the pump.

(2) Remove the hexagonal nuts and bolts from the front casing and remove the front casing from the bracket.

(3) Pull the impeller forward for removal.

Careful handling of each part should ensure that no damage can occur.

(4) Pull the rear casing forward for removal.

## 2) Assembly

(1) Assemble the pump in the reverse order to disassembly.

(2) Before assembly clean all parts so that no foreign particles are present in or around the parts. Make sure that the parts are not scratched and that the magnets are not contaminated with metallic particles.

(3) Always mount new O-rings after disassembly.

(4) Tighten all bolts and nuts equally and make sure they are not over tightened.

## 10. Exploded view

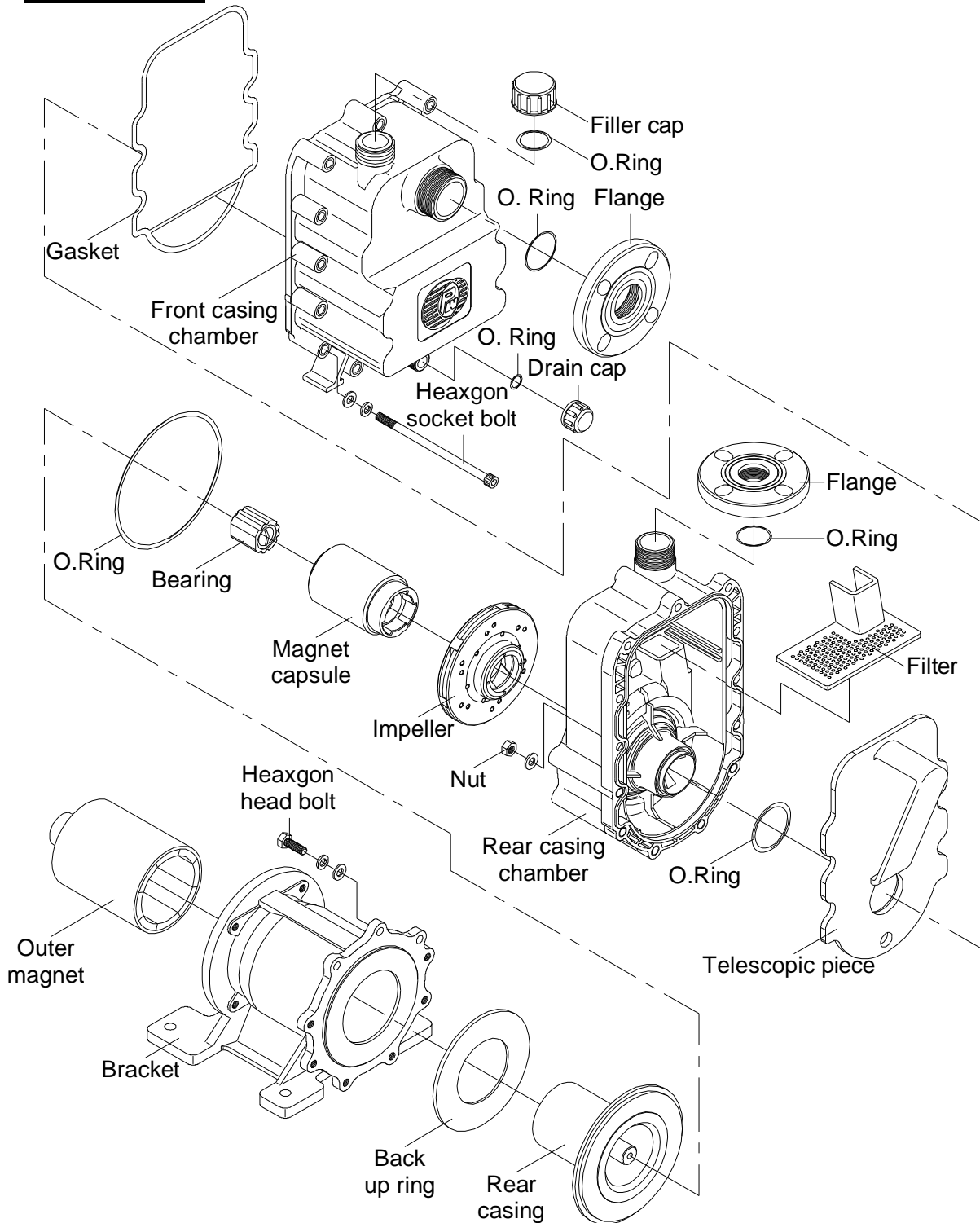



## 11. Troubleshooting

<b>Trouble</b>	<b>Cause of Trouble</b>	<b>Troubleshooting</b>
Insufficient pumping /Unable to pump.	The inlet pipe is longer.	Shorten length of the inlet pipe.
	Pump rotates in reverse is wrong direction.	Check the connected wires.
	Air enters from the inlet pipe	Inspect the connection section of the inlet pipe is sealed. Check to ensure the liquid level.
	The magnet coupling has disconnected.	Inspect the inside of the pipe for foreign matters. Measure the current to ensure is not overload.
	The inlet (or discharge) pipe is blocked with foreign matter.	Clean the inlet (or discharge) pipe and remove the foreign matter.
	Resistance in the discharge pipe.	Remove the foreign matter and inspect whether any damage of discharge pipe.
	The inlet (or discharge) flange is deformed or broken.	Exchange the flange to a new one.
Pump vibrates.	The motor bearing is worn.	Exchange a bearing or a motor.
	The pump bearing is melted or worn.	Replace a bearing.
	The spindle or the magnet capsule is damaged.	Replacement.
	The mounting is not fixed firmly.	Retighten the mounting.
	The installation bolts and nuts are loosened.	Retighten bolts and nuts.
	The impeller contacts with the magnet capsule fixed part.	Replacement.
The motor overheats	Overload.	Inspect to see if the correct specific gravity and viscosity of the liquid are suitable.
	The ambient temperature is high.	Keep the motor well ventilated.
	The voltage has dropped greatly.	Inspect the voltage and the frequency.



1300 1 GLOBAL  
sales@globalpumps.com.au  
globalpumps.com.au