

# Standard Series

## SS8x6-201130

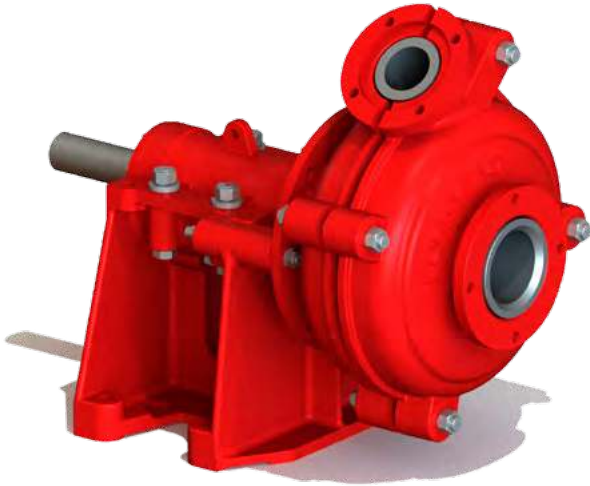

Suction	203 mm (8")
Discharge	152 mm (6")
Maximum RPM	1300
Sealing system	Expeller
Impeller material	Rubber
Liner material	Rubber
Throat bush	Rubber
Maximum motor power	120 kW
WeightBare shaft pump	2733 kg

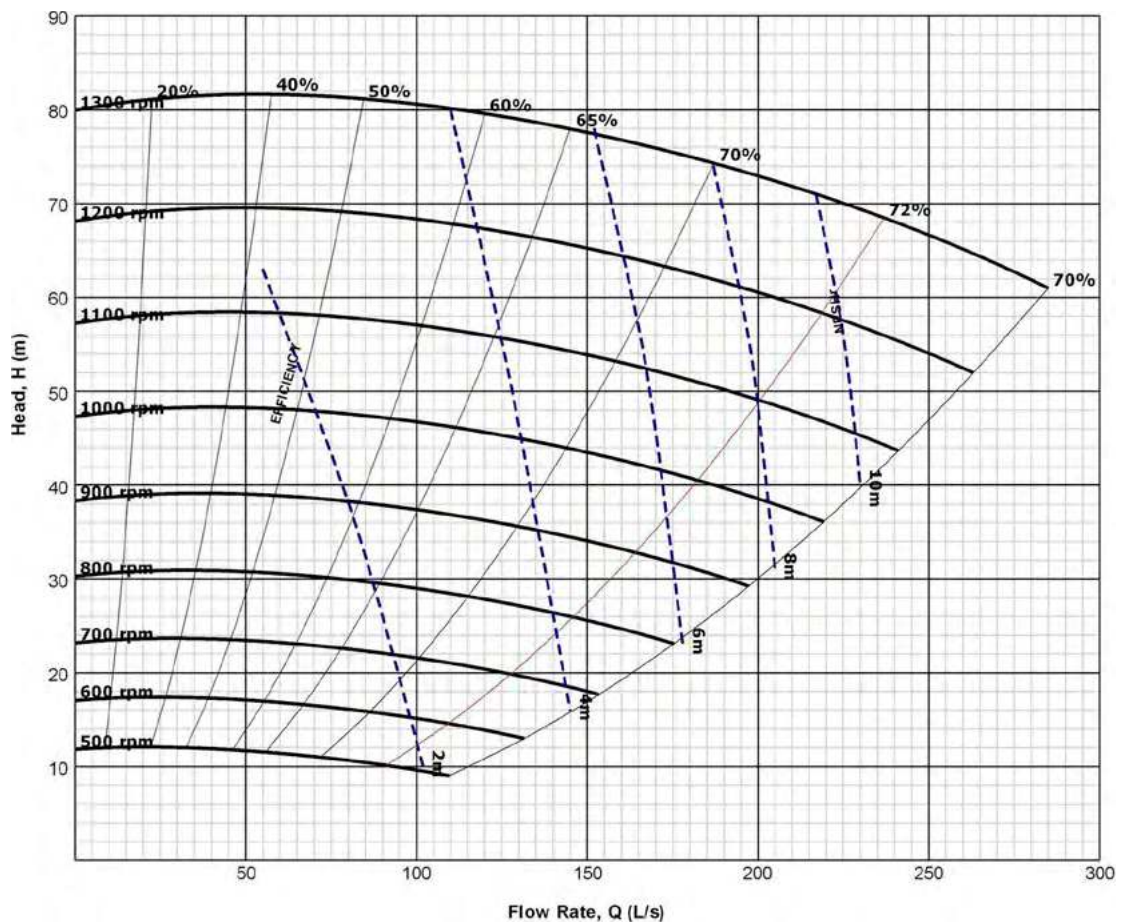

**NOTE** This information is for guidance/reference only. For application specific drawings and curves, please contact your nearest authorised distributor at [slurrypro.com](http://slurrypro.com)

# Standard Series

## SS8x6-201130

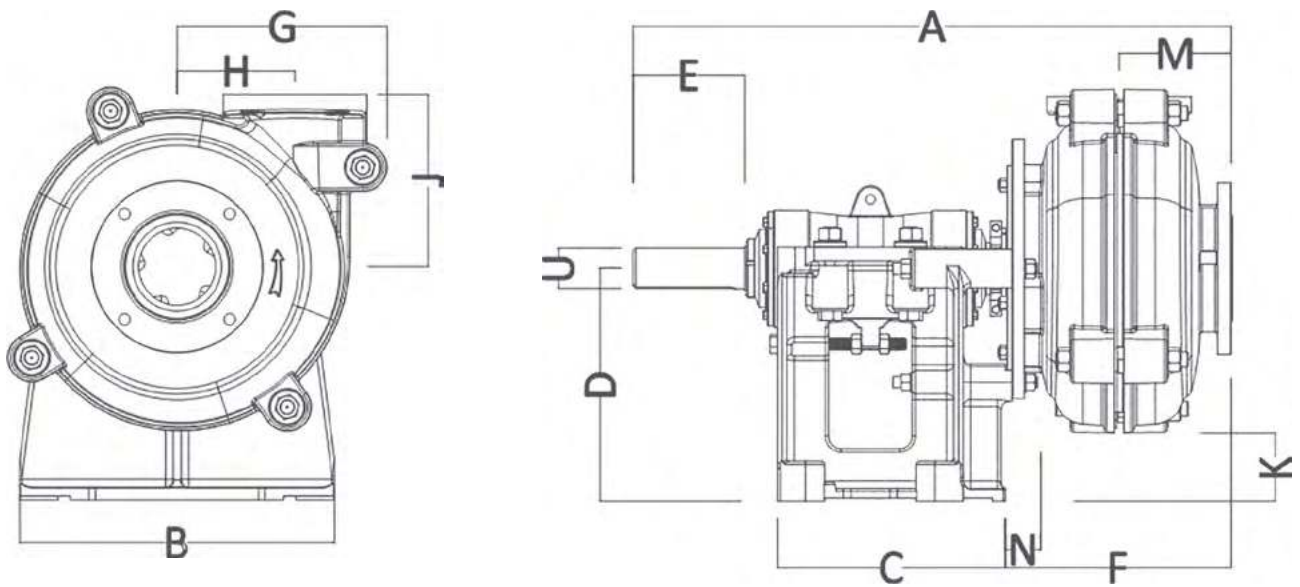

A	D	E	F	G	H		
1302	622	448	457	222	557	551	318
J	K	L	M	N	U	Key size	
460	0	62	292	82	80	22 x 14	

All values in millimetres (mm)