

Standard Series

SS6x4-01000

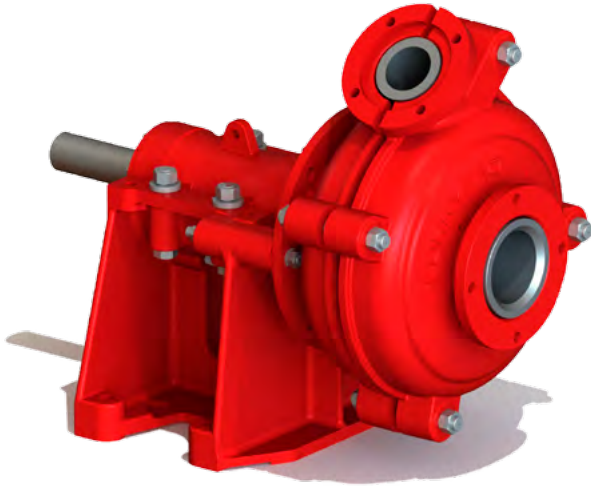

Suction	152 mm (6")
Discharge	101 mm (4")
Maximum RPM	1709
Sealing system	Standard gland packing
Liner material	High chrome
Impeller material	High chrome
Throat bush	High chrome
Maximum motor power	120 kW
Weight-Bare shaft pump	1500 kg

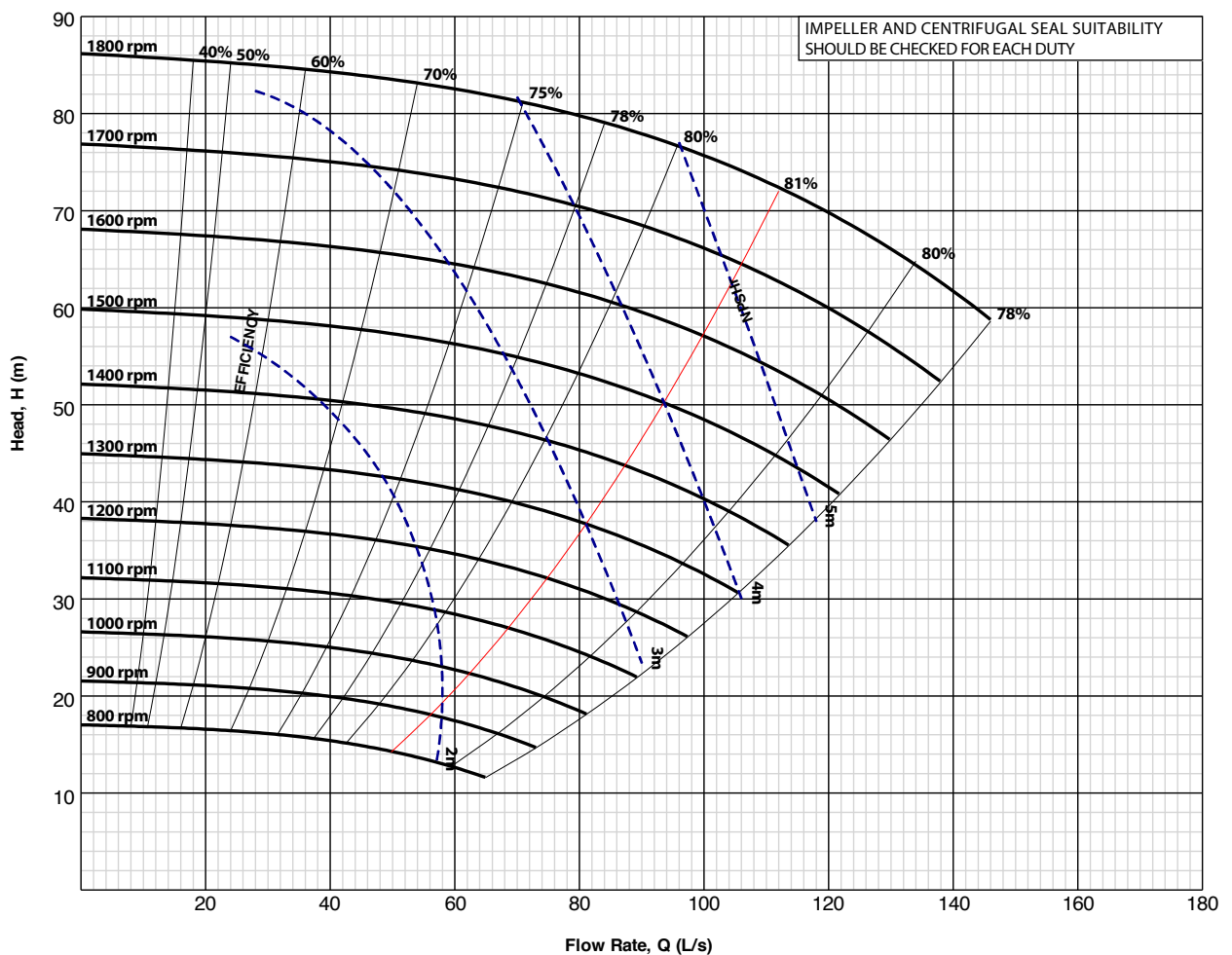

NOTE This information is for guidance/reference only. For application specific drawings and curves, please contact your nearest authorised distributor at slurrypro.com

Standard Series

SS6x4-01000

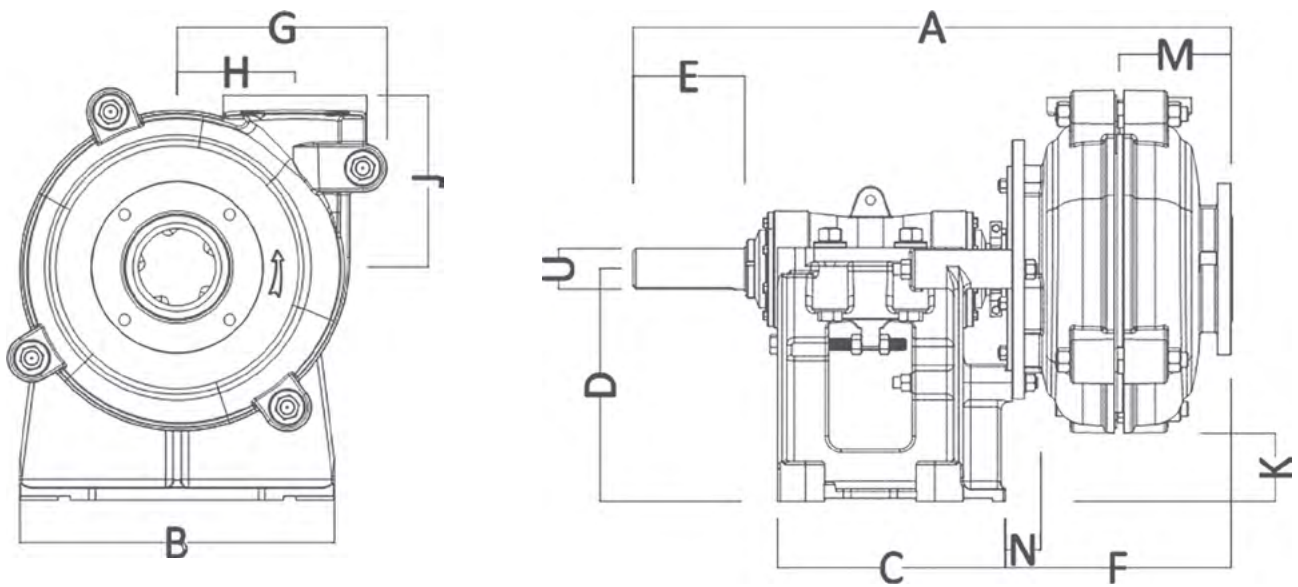

A	B	C	D	E	F	G	H
1178.05	622.05	448.06	456.95	222	433.07	405.89	229.11
J	K	L	M	N	U	Key size	
338.07	137.92	0	218.95	75.18	80	22 x 14	

All values in millimetres (mm)