

# Standard Series SS2x1.5-201105

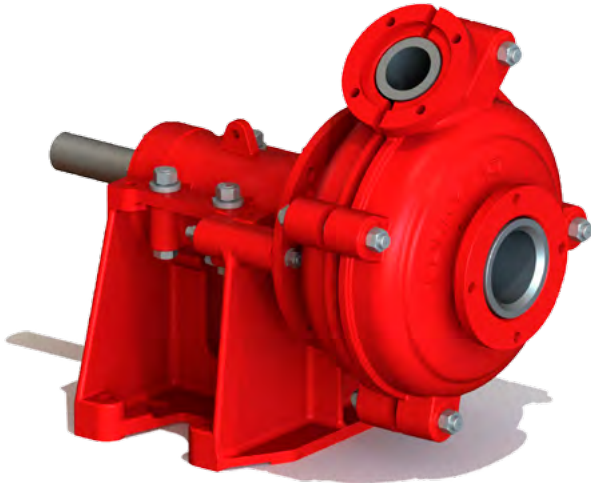

<b>Suction</b>	50.8 mm (2")
<b>Discharge</b>	38 mm (1.5")
<b>Maximum RPM</b>	2600
<b>Sealing system</b>	Expeller
<b>Impeller material</b>	Rubber
<b>Liner material</b>	Rubber
<b>Throat bush</b>	N/A
<b>Maximum motor power</b>	15 kW
<b>Weight-Bare shaft pump</b>	156 kg

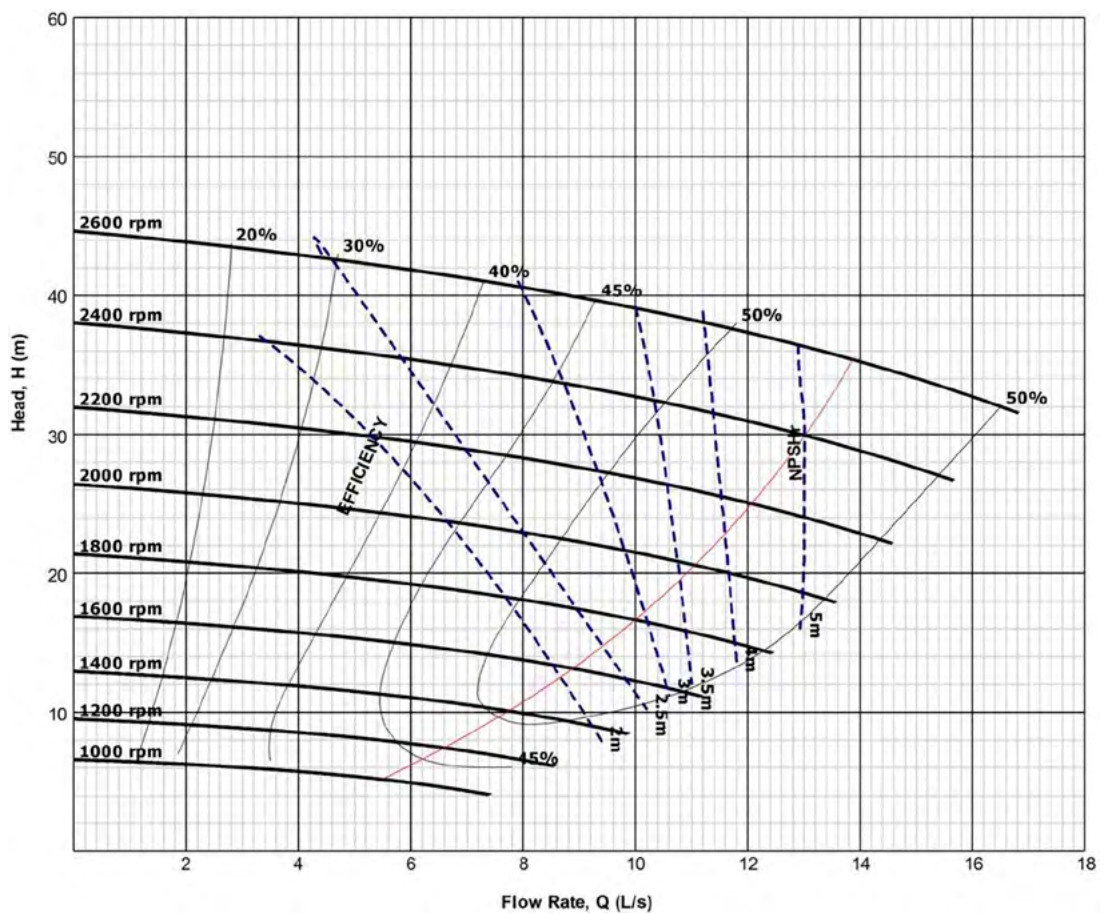

**NOTE** This information is for guidance/reference only. For application specific drawings and curves, please contact your nearest authorised distributor at [slurrypro.com](http://slurrypro.com)

# Standard Series

## SS2x1.5-201105

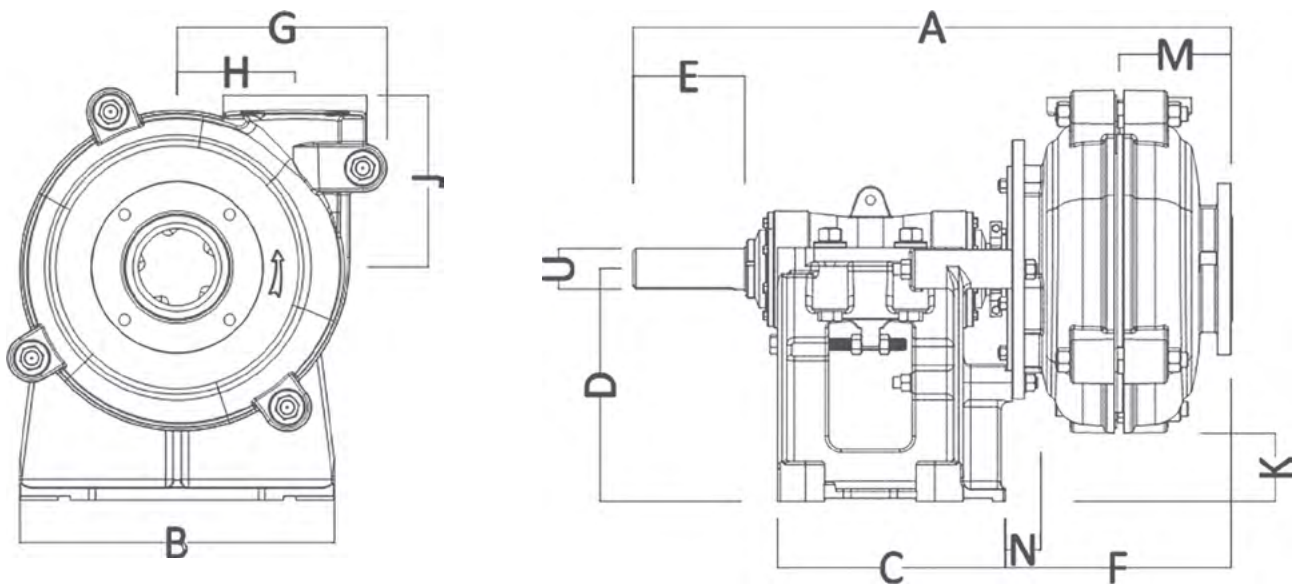

A	B	C	D	E	F	G	H
592.07	294.89	247.9	197.1	78.99	216.92	202.95	114.05

J	K	L	M	N	U	Key size
183.9	33.27	0	114.05	21.84	28	8 x 7

All values in millimetres (mm)