

# Pump series ZS

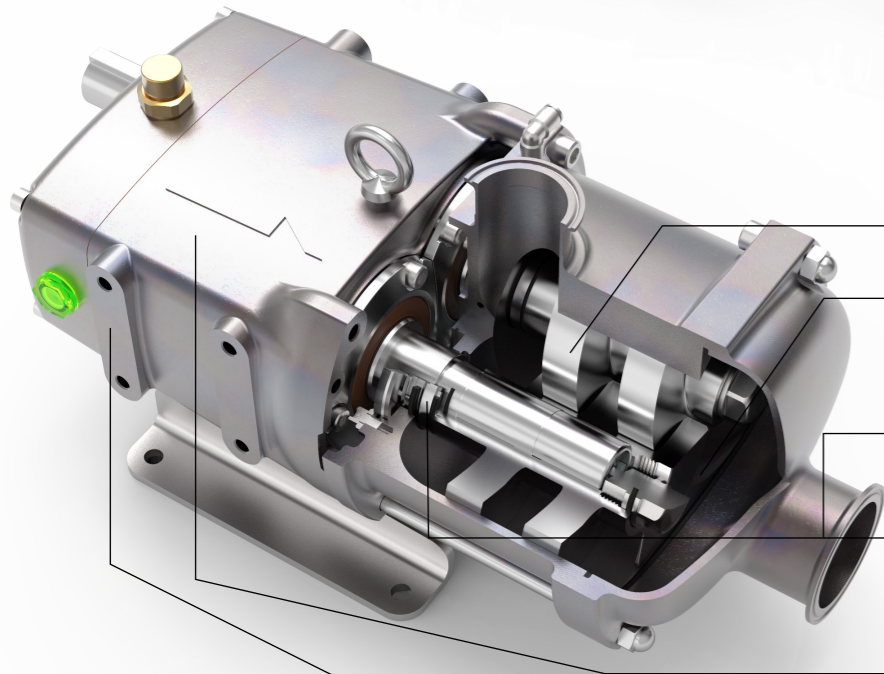

## Characteristics

Packo twin screw pumps offer maximum flexibility in terms of the type of application, as well as the nature of the medium to be pumped. Exceptionally good hygiene and cleanability make this type of pumps more and more popular.

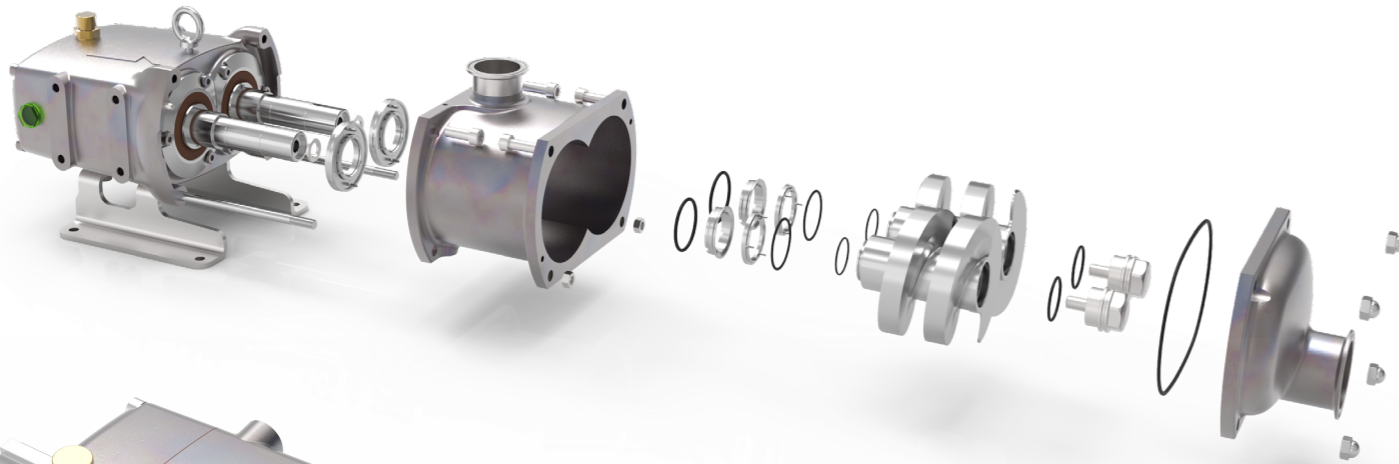

- ZS**
- 1 Different selectable screw pitches allow an exact adjustment to flow rate, pressure and particle size.
  - 2 Due to the constant geometry of the conveying chamber, an extremely gentle transport is ensured, another advantage is the low-pulsation conveying characteristics.
  - 3 Available with various sealing arrangements: single, flushed, double, triple lip seal, etc. which are interchangeable.
  - 4 Compact seal design enables large cross-sections in the outlet area of the pump, minimizing the influence of a narrow bottle neck on the medium, due to changes in flow speeds.
  - 5 Food grade oil-filled gearbox increases bearing lifetime and requires minimal service effort. Ball bearings generate very low heat, helical and grinded gears guarantee smooth operation.
  - 6 Investment cast stainless steel gearbox.

## Application areas

The Packo ZS twin screw pumps were designed for pumping low to high viscous and gaseous liquids in hygienic applications in dairies, breweries, the pharma and cosmetics industry and bakeries. The ZS is the ideal positive displacement pump for gentle pumping of viscous liquids without damaging contained solids, such as fruit in yoghurt, nuts in ice cream, etc. Thanks to the wide range of allowable speed, the ZS pump can also be used as CIP+ pump, making a by-pass centrifugal pump redundant.

## Your benefits

### Cleaner

- Certified to 3A and EC1935/2004
- Wetted surfaces with Ra < 0.8 µm
- Wetted parts in SS316L
- Gearbox in stainless steel
- High speed range allows adjustment to nearly each viscosity
- Pump can be operated bi-directional
- Different screw options to adapt perfectly to each application
- 2 in 1 Feature Convey and CIP with the same pump
- Designed without dead spaces, O-ring grooves without dead corners
- Wetted parts of mechanical seals directly in the product stream
- Pump casing with large corners avoids product sticking and simplifies the cleaning process
- Maximum product protection
- No change in chamber geometry, thus no product squeezing
- Linear conveying characteristic, since direction of flow is identical to the direction of rotation
- Constant pressure build up
- Smooth, low-shear pumping characteristics

### Highest flexibility

- Connections according to customer requirements
- Heating/ Cooling jacket for casing and, many more options available

## Pump series

### Performances

	ZS
max. flow rate	100 m³/h
max. viscosity	1.000.000 cP
max. differential pressure	12 bar
max. temperature	150°C

### Technical specifications

materials wetted parts	stainless steel 316L
seal configuration	single, flushed, double mechanical seal, triple lipseal
available material O-ring	EPDM, FKM, FFKM
connections	sanitary and industrial fittings
surface finish	food quality, internal welds hand polished to 0.8 µm
certificates & legislation	

## Pump curves for ZS

