



**Global
Pumps**

solving tough
challenges



**SLURRYPRO ELITE
MECHANICAL SEAL**

INTRODUCING THE SLURRYPRO ELITE MECHANICAL SEAL



GLOBAL PUMPS BELIEVE THAT PERFECTION IS ACHIEVED NOT WHEN THERE IS NOTHING LEFT TO ADD, BUT WHEN THERE IS NOTHING LEFT TO TAKE AWAY

From this principle, the SlurryPro Elite Mechanical Seal was developed to be able to withstand arduous conditions without complexity.

The SlurryPro Elite is a modular design featuring patented conical, diamond-coated seal faces, currently achieving up to six times the service life of traditional cartridge seals.

- water usage is eliminated altogether or reduced to 0.2 L/min in harsh conditions;
- no need for shaft cooling;
- no more water leakage;
- no more stressing about the condition of the gland water pumps;
- no more chance of bearing barrel failure from the leaking gland water;
- no more adjusting gland followers on live pumps.



SlurryPro Elite diamond faced mechanical seals have outlasted traditional cartridge seals

With the fitters in mind, this mechanical seal has additional advantages including, but not limited to:

- ability to accommodate greater misalignment;
- greater vibration tolerance;
- modular design for faster installation, takes the place of the stuffing box;
- conical faces enhance fluid circulation for reduction of build-up of solid particles;
- easily refurbished, as you can replace the seal faces and o-rings.



Maintenance can be easily be done by site teams, rather the need to return them to the manufacturer for repair.

The new SlurryPro Elite mechanical seal (*Figure 1.*) offers flexibility when specifying new pumps or upgrading existing pumps.

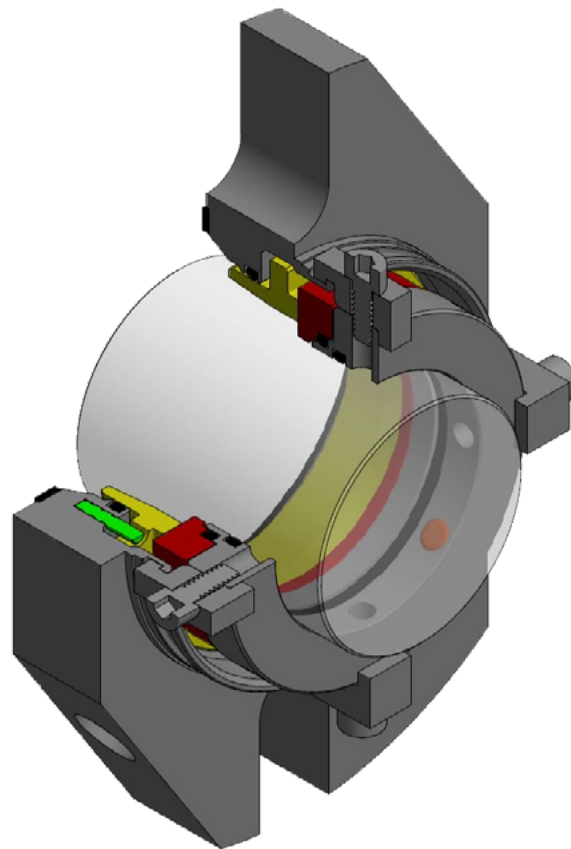

Figure 1. The SlurryPro Elite mechanical seal with patented conical design

HOW GLOBAL PUMPS CAN HELP YOU



WITH OVER 40 YEARS EXPERIENCE, YOU'RE IN SAFE HANDS

Global Pump's innovative designs and in-depth knowledge of pumps will ensure a complete solution to maximise productivity and reduce operational costs. Our team are capable of building and customising complete pumping solutions – so you're in safe hands.

TESTIMONIAL

Shaun, a Maintenance Planner in Cloncurry, Queensland, recently purchased two mechanical seals from Global Pumps. They were installed a few months ago, with no problems to date.

"Haven't had to pull them apart or touch them since installation several months ago".

To learn more about the range of seals available, [contact the team](#) at Global Pumps.

 1300 1 GLOBAL

 sales@globalpumps.com.au

 12 Selgar Avenue
Tonsley, South Australia 5042

OPINION DISCLAIMER

The views and opinions expressed in this white paper are solely those of the original author and other contributors. These views and opinions do not necessarily represent those of Global Group, Global Pumps and Global Water staff and/or any/all contributors to the website.

