

The Global Water range of Kwikalarm™ Alarm Panels were developed to provide a level alarm warning in septic tanks, water storage tanks, pump sumps and dump pits.



Global Water Kwikalarm™ Alarm Panels are designed for easy installation and incorporate low voltage float switches and a cable and plug for connection to a standard power outlet.

The alarm panel is designed to be mounted inside the dwelling or office and incorporates a red fault light and an audible alarm with a muting function.

The Kwikalarm™ model K124 has one float switch which can be configured for high or low level alarm.

The Kwikalarm™ model K224 is designed for septic holding tanks and has two floats and one solenoid. The first float activates an alarm at high level and the second float activates the solenoid at an extra high level and shuts off the water supply to the dwelling.

The float switches are available with 10m or 20m cable lengths.

To specify or to order Global Water Kwikalarm™, simply quote the model number followed by the float switch cable length required. Example: K224/10.

Dimensions

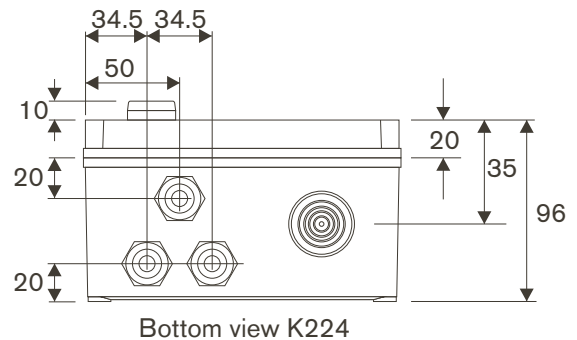
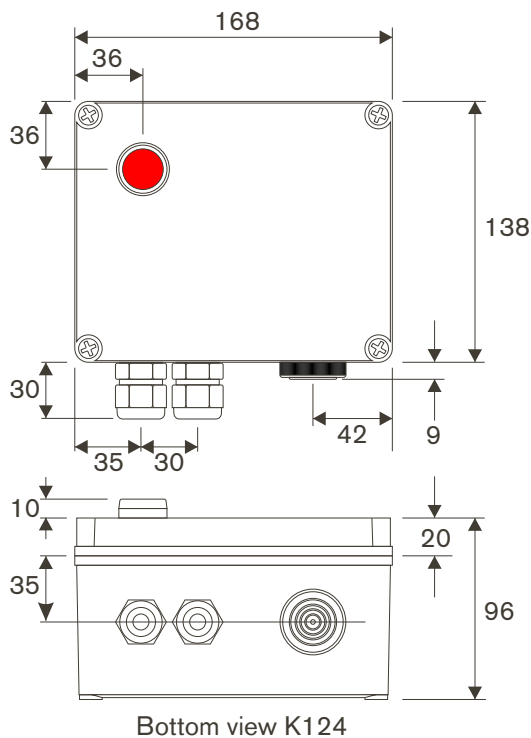

Applications

- pump pits
- septic tanks
- water supply storage
- flood protection
- bunded areas
- dump tanks.