

Ideal for pumping water, raw sewage with sludge and high rag content, industrial process water and stormwater in municipal and heavy duty commercial applications.

Features

- double mechanical shaft seal in oil bath with hard faced silicon carbide/ceramic seal on pump side
- open single non-clog channel impeller with spiral bottom plate for rag handling
- rugged cast iron construction with stainless fasteners
- seal fail detection probe option.



Dimensions (all measurements mm)

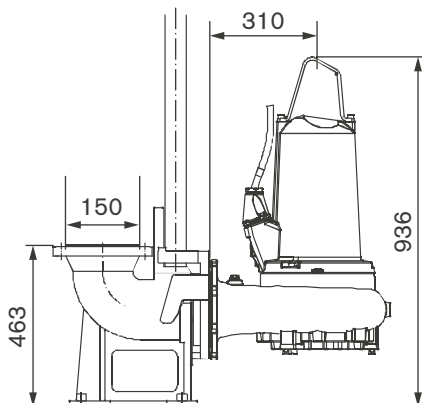

Technical data

Outlet (mm)	150 DIN flange
Max flow rate (L/s)	80
Max head (m)	18
Max liquid temperature (°C)	40
∅ Solids (mm)	100
Power (kW)	6
Current (A)	13.6
Voltage (V)	415
Speed (RPM)	1470
Casing	Cast iron
Impeller	Cast iron chokeless
Motor housing	Cast iron
Protection	IP67
Cable details	10 m length, H07 RN-F
Mounting	Guide rail kit optional
Weight (kg)	187

Performance curve

