

Ideal for pumping effluent, stormwater run-off and contaminated drainage water in light commercial applications, particularly where there is the likelihood of solids or stringy material.



### Technical data

Outlet (mm)	50 BSP
Max flow rate (L/s)	10.8
Max head (m)	11
Max liquid temp (°C)	40
Ø Solids (mm)	50
Power (kW)	1.1
Current (A)	6.9
Voltage (V)	240
Speed (RPM)	2900
Casing	Epoxy electro coated cast iron
Impeller	Stainless vortex
Motor housing	Stainless steel
Protection	IP68
Cable details	10 m length, H07RN-F
Mounting	Free-standing only
Weight (kg)	18.5

### Dimensions (all measurements mm)

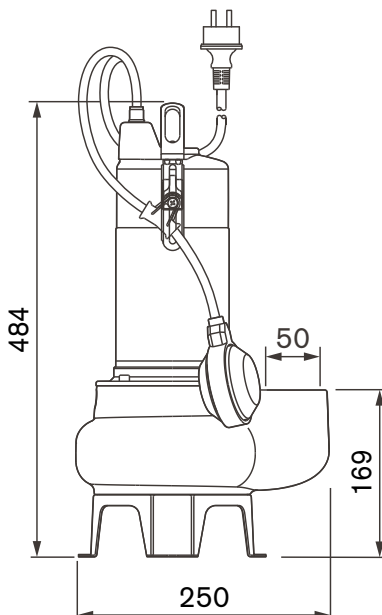

### Performance curve

