

# DrainAce™ Compact

## Undersink pump station

The DrainAce Compact undersink pump station is the ultimate solution for applications where gravity discharge from a sink or other appliance to a sewer connection or treatment device (e.g. grease arrester) is not available.

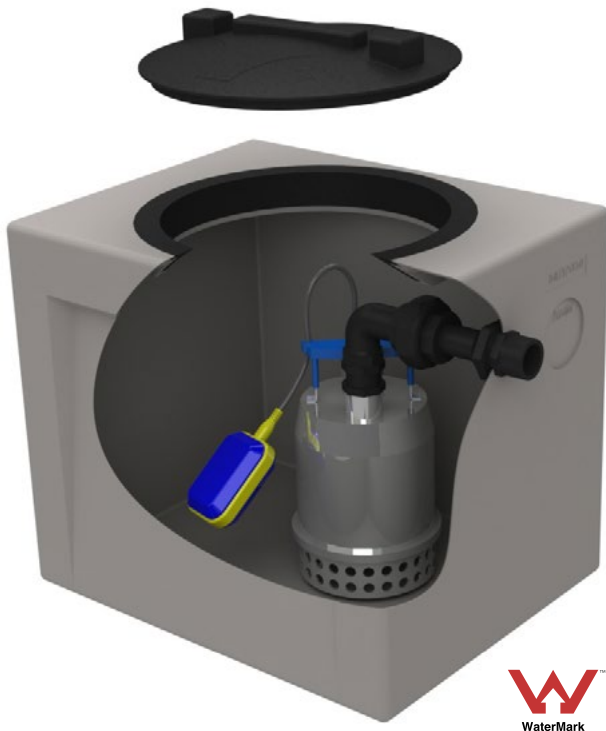

Prime examples of the uses of a DrainAce Compact pump station are restaurants, boardrooms, basements of high-rise buildings, laboratories, doctor and dental surgeries, construction sites and portable buildings. Units are also available for greasy waste discharge to grease arrestors, and can handle discharge up to 40 °C from dishwashers and glass washing machines.

Designed for quick and simple installations, the unit fits neatly into a single cupboard below a sink, and runs with virtually no noise. All in-tank plumbing is included with a discharge outlet at one end, with provision for vent and inlet connections on either end.

The chamber is moulded from chemical-resistant polyethylene and fitted with a rugged stainless steel 240 V Global Water automatic submersible pump capable of passing up to 10mm soft solids.

---

### Features

- large capacity polyethylene tank for emergency storage and heat dilution
- gas-tight screwed lid
- quick-connect Uniseal® fittings for inlet and vent
- discharge ball valve
- Global Water stainless steel pump with float switch
- quick-release waterproof electrical connection for easy pump removal
- high level alarm option available

To specify or order a DrainAce pumping system from Global Water, simply quote the DrainAce Model GPD followed by the pump model number.

## Specifications

Model	Pump size	Ø Solids (mm)	Volts (V)	Power (kW)	Amps (A)	Outlet (mm)
GPD200	GPD32-25	10	240	0.25	1.9	32
GPD300	GPD32-55	10	240	0.55	3.5	32

\*To order with an optional high level alarm, add 'HL' to model number, e.g. 'GPD300HL'

## Specification drawing

- ① 90 L polyethylene tank
- ② polyethylene gas-tight screw lid
- ③ Global Water automatic submersible pump
- ④ built-in non return valve
- ⑤ barrel union on internal pipework for pump removal
- ⑥ 32 mm discharge true union ball valve to allow system isolation and complete tank removal
- ⑦ 50 mm inlet/vent connections with Uniseals supplied
- ⑧ IP68 quick connector for ease of pump removal
- ⑨ 3 m power cable - suits standard single phase 10 A GPO

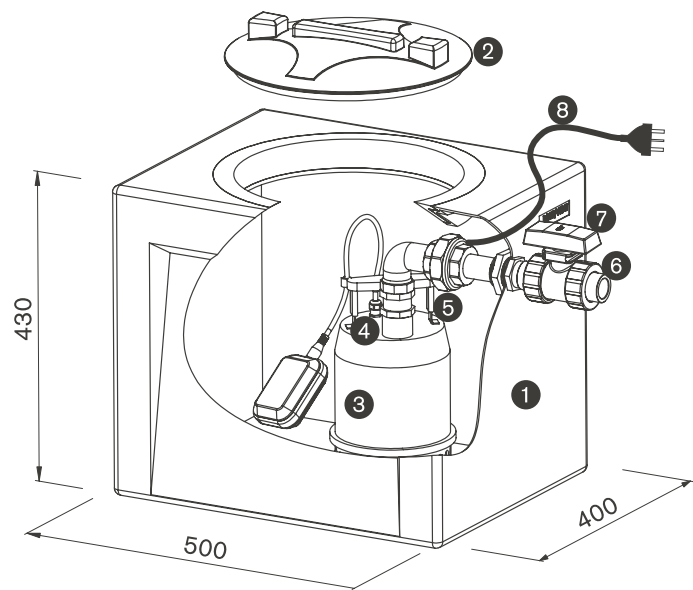

All measurements in mm

## Performance curve

